

The J&M Model 3062 Fixed Speed Top Drive Rotary Head

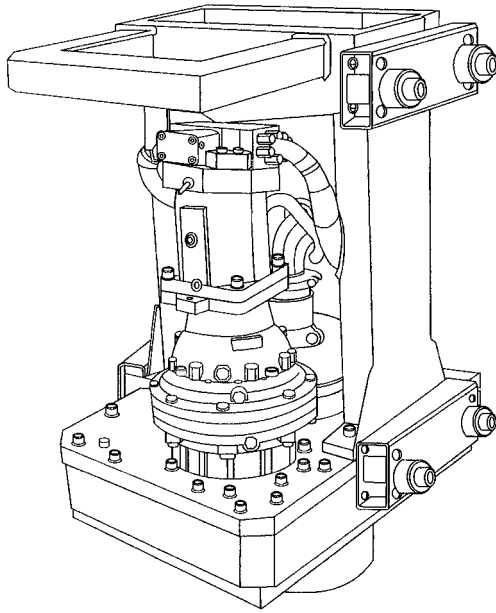

Heavy-duty single-motor design maximizes uptime & simplicity

- ◆ Single-speed, fixed-torque design maintains maximum drilling speed and maximum available torque throughout the entire drilling cycle to maximize drilling production.
- ◆ State of the art Chevron Clarity non-toxic and biodegradable hydraulic oil.
- ◆ Oversized components (designed for 35,000 ft-lbs of output torque) ensure both maximum component life and unit uptime.
- ◆ Simple single-motor design provides unmatched reliability and simplifies unit serviceability and maintenance.
- ◆ Convertible rotary head allows simple and inexpensive conversion to higher torque design (22,000 ft-lb) when job requirements dictate more torque.
- ◆ Remote electric pendant control includes operational mode selection switches, engine speed control for fuel efficiency and emergency stop for personnel safety.
- ◆ Highly efficient Commercial Intertech pump and Rexroth piston motor provides excellent hydraulic power transfer and horsepower efficiency.
- ◆ Open-loop hydraulic system provides jobsite condition reliability and ensures maximum efficiency, maximum reliability and simpler, quicker unit serviceability.
- ◆ Optionally available digital radio remote provides total operator freedom of movement.
- ◆ Made in the USA by the industry's most technologically innovative manufacturer of rotary heads and foundation equipment since 1974.

ROTARY HEAD

Maximum torque	15,200 ft-lbs (2101 kg-m)
Maximum speed	65 rpm (65 rpm)
Maximum crowd force	35,000 lbs (15,875 kg)
Rotary swivel ID (standard)	3 in (76 mm)
Rotary swivel ID (optional)	4 in (102 mm)
Height	52 in (1320 mm)
Width	26 in (660 mm)
Depth	38 in (965 mm)
Weight (without hoses)	3,000 lbs (1360 kg)
Hydraulic hose length	100 ft (30 m)
Hydraulic hose weight	500 lbs (225 kg)

POWER UNIT

Engine	Caterpillar 3116TA
Power	230 HP (171 kW)
Operating speed	2,600 rpm (2600 rpm)
Drive pressure	5,000 psi (345 bar)
Drive flow	70 gpm (265 lpm)
Weight (w/ full fluid & fuel)	9,400 lb (4264 kg)
Length	126 in (3200 mm)
Width	60 in (1525 mm)
Height	76 in (1930 mm)
Hydraulic reservoir	275 gal (1040 l)
Fuel capacity	122 gal (460 l)

AVAILABLE ACCESSORIES

Lead adapters to fit any size of lead from 26 inch and above or spud guides to fit 14 inch H-beams.
 Available with 3" or 4" air/grout swivels and output shaft flange adapters to match your drill stem connection.
 This unit is also available in an Auto-Torque configuration. See the Model 35AT for more information.

APPLICATION NOTES

An appropriate shock-sub is recommended for DTH hammer applications.



1601 Banksville Road Pittsburgh Pa 15216-3205

PH: 866-462-PART / 412-341-8190 / 412-720-5175

E-Mail: info@jandm-usa.com FAX: 412-341-8192