

The J&M Model 5050 Two Speed Top Drive Rotary Head

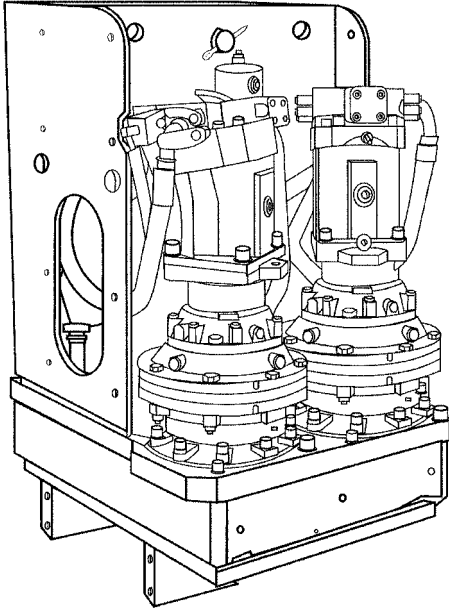

Two speed control maximizes drilling performance from top to bottom

- ◆ The most efficient and productive rotary head available in its torque class.
- ◆ Two speed/torque ranges allow operator selection of optimum drilling performance.
- ◆ Specially designed two speed valve facilitates on the fly shifting.
- ◆ State of the art Chevron Clarity non-toxic and biodegradable hydraulic oil.
- ◆ Simple dual-motor design provides superior reliability and simplifies unit serviceability and maintenance.
- ◆ Optionally available digital radio remote provides total operator freedom of movement.
- ◆ Remote electric pendant control includes engine speed control for fuel efficiency and emergency stop for personnel safety.
- ◆ Hollow output shaft accepts up to 6 inch diameter air or grout swivels.
- ◆ Advanced technology, high pressure, gear motors for simple reliability.
- ◆ Power unit can also be used with other J&M products such as vibratory hammers and hydraulic impact hammers.
- ◆ Open-loop hydraulic system provides jobsite condition reliability and ensures maximum efficiency, maximum reliability and simpler, quicker unit serviceability.
- ◆ Made in the USA by the industry's most technologically innovative manufacturer of rotary heads and foundation equipment since 1974.

ROTARY HEAD

Maximum torque	50,000/25,000 ft-lbs (76 kg-m)
Maximum speed	25/50 rpm
Maximum crowd force	80,000 lbs (36290 kg)
Rotary swivel ID (standard)	3 in (76 mm)
Rotary swivel ID (optional)	4 in (102 mm)
Height	52 in (1320 mm)
Width	26 in (660 mm)
Depth	38 in (965 mm)
Weight (without hoses)	4,400 lbs (1995 kg)
Hydraulic hose length	100 ft (30 m)
Hydraulic hose weight	500 lbs (225 kg)

POWER UNIT

Engine	Caterpillar 3306TA
Power	335 HP (250 kW)
Operating speed	2100 rpm (2100 rpm)
Drive pressure	5,500 psi (379bar)
Drive flow	87 gpm (330 lpm)
Weight (w/ full fluid & fuel)	10,485 lbs (4755kg)
Length	126 in (3200 mm)
Width	60 in (1525 mm)
Height	68 in (1730 mm)
Hydraulic reservoir	270 gal (1020 l)
Fuel capacity	110 gal (415 l)

AVAILABLE ACCESSORIES

Lead adapters to fit any size of lead from 26 inch and above or spud guides to fit 14 inch H-beams.

Output shaft flange adapters to match your drill stem connection.

This unit is also available in the Auto-Torque configuration. See the Model 55AT for more information.

APPLICATION NOTES

An appropriate shock-sub is required for DTH hammer applications.



1601 Banksville Road Pittsburgh Pa 15216-3205

PH: 866-462-PART / 412-341-8190 / 412-720-5175

E-Mail: info@jandm-usa.com FAX: 412-341-8192