

J&M Model 416S Vibratory Driver/Extractor

LOW HEAD ROOM

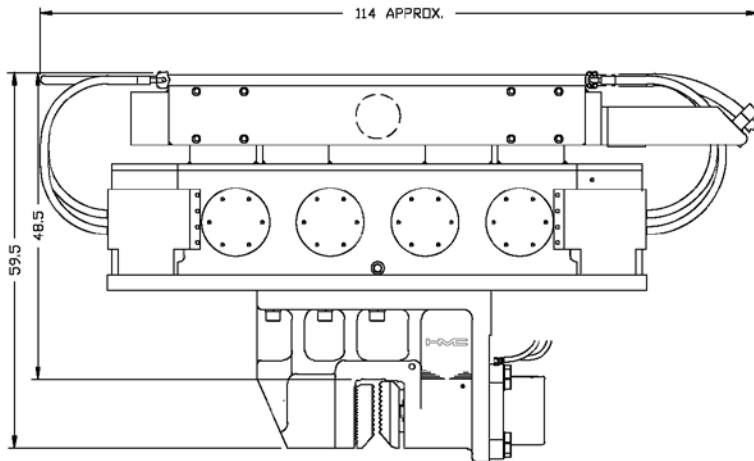

- High moment + low mass = maximum amplitude.
- Minimum height. and weight.
- 10 ton elastomeric suspension.
- Environmentally friendly hydraulic fluid is standard.
- Remote electric pendant with engine throttle.
- Emergency stop buttons on pendant & power unit.
- Duplicate controls on panel eliminates downtime.
- Full range of standard piling clamps.
- Clamp has internal lock valve for safety.
- Clamp cylinder machined from solid – no leaks.
- Fully enclosed power unit with central lift.
- High quality, super efficient, piston pumps & motors.
- Optional digital radio remote control.
- Easily converted to normal HMC Model 26.
- Standard power unit runs full range of hydraulic tools.
- Proven reliable, open loop, hydraulic system.

Built in America – Building America

VIBRATOR		POWER UNIT		
Eccentric moment	2,200 in-lbs (2535 kg-cm)	Engine	Caterpillar 3306TA	
Frequency	1600 vpm (1600 vpm)	Power	335 HP (250 kW)	
Centrifugal force	80 tons (710 kN)	Operating speed	2100 rpm (2100 rpm)	
Amplitude (free hanging)	0.98 in (25 mm)	Drive pressure	5,000 psi (345 bar)	
Max line pull for extracting	10 ton (355 kN)	Drive flow	87 gpm (330 lpm)	
Weight (no clamps or hoses)	5,600 lbs (3360 kg)	Clamp pressure	4,300 psi (295 bar)	
Non-vibrating weight	1,900 lbs (1315 kg)	Clamp flow	5.2 gpm (20 lpm)	
Height (without clamp)	35 in (1780 mm)	Weight (w/ full fluid & fuel)	9,600 lbs (4355 kg)	
Length	114 in (2415 mm)	Length	126 in (3200 mm)	
Width	17 in (430 mm)	Width	60 in (1525 mm)	
Throat width	14 in (355 mm)	Height	68 in (1730 mm)	
Hydraulic hose length	100 ft (30 m)	Hydraulic reservoir	270 gal (1020 l)	
Hydraulic hose weight	850 lbs (385 kg)	Fuel capacity	110 gal (415 l)	

HYDRAULIC CLAMPS:	Standard Universal Clamp	Single Sheet Z-Pile Clamp	Casing Clamps w/ 7' Beam	Concrete & Small Pipe Timber Clamp
Clamping force	125 tons (1112 kN)	125 tons (1112 kN)	160 tons (1423 kN)	53 ton (470 kN)
Weight	2,150 lbs (975 kg)	3,190 lbs (1447 kg)	3,260 lbs (1479 kg)	4,970 lb (2255 kg)
Length	45 ¾ in (1160 mm)	48 ½ in (1230 mm)	110 in (2795 mm)	43 in (1095 mm)
Width	12 in (305 mm)	18 in (460 mm)	13 ¾ (350 mm)	27 in (685 mm)
Height	37 ¾ in (960 mm)	41 ¼ in (1050 mm)	26 in (660 mm)	79 in (2005 mm)



1601 Banksville Road Pittsburgh Pa 15216-3205

PH: 866-462-PART / 412-341-8190 / 412-720-5175

E-Mail: info@jandm-usa.com FAX: 412-341-8192